



To ensure your
semiconductors keep cool.

COOLING SOLUTIONS BY ETRONICS

etronics – DAU's Swiss distributing
partner for 20 years.



Five good reason for air and water heat sinks from etronics.



WE CAN SOLVE ALMOST EVERY THERMAL PROBLEM.

Whether it is a flow accelerator, a DAU lock or a vacuum-brazed heat sinks or other innovations, high-performance semiconductors ensure excellent heat distribution and dissipation.



FLEXIBLE PLACEMENT OF THE SEMICONDUCTORS.

Semiconductors can be installed on the surface as required because of the inner workings of the DAU heat sinks, in particular the vacuum-brazed heat sinks.



CUSTOMISED HEAT SINK DESIGNS.

Our channel design is also flexible. This results in an even channel flow, a lesser drop in pressure and excellent heat dissipation.



QUALITY IS OUR UTMOST PRIORITY.

Our philosophy is simple, if it is not tried and tested, it is not sufficient: Various testing procedures for impermeability, temperature distribution and water flow ensure quality of the highest standard.



PRACTICE MAKES PERFECT.

Tradition also benefits from innovation: DAU has over 45 years of experience in the design and production of cooling solutions.

A host of possibilities under one roof.

We design, develop and produce cooling solutions according to customers specification. Based on your requirements we use air and liquid cooling heat sinks. For technical details please refer to the cooling solutions catalogue by DAU.

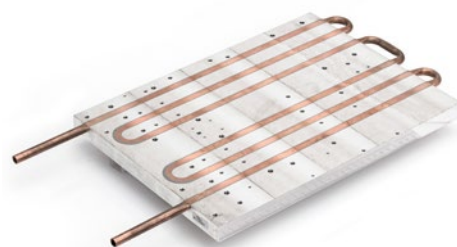

Vacuum-brazing: Technology you can count on.

More and more customers opt for vacuum-brazing as it has various advantages compared to conventional welding techniques:

- **the cooling circuit can be adapted to the geometry of the semiconductors**
- **extremely low thermal resistances**
- **leak-free, high-strength and extremely durable joints (bursting pressure of over 80 bar)**
- **no change of the material structure**
- **no flux residues**
- **extremely reliable and long service life**
- **the mounting holes do not influence the thermal performance**



Vacuum brazing furnace at DAU

The computerised vacuum-brazing furnace developed especially for DAU is used to solder the pre-installed parts to the cooling plates in a vacuum.

Innovative. Highly effective. Compatible. The VBA series.

The VBA series was developed for applications where there are above-average thermal requirements. While maintaining a very low pressure drop, this new and innovative liquid system provides extremely low thermal resistances. The VBA series is compatible with all conventional power semiconductors and stacked semiconductors.

By milling, it is possible to adapt the position, size and length of the cooling channels to the position with the highest thermal load and to the predefined and/or given values such as the Reynolds number, the pressure drop and the volume flow when vacuum-brazing.

Thermal Resistance Curve VBA-110-300

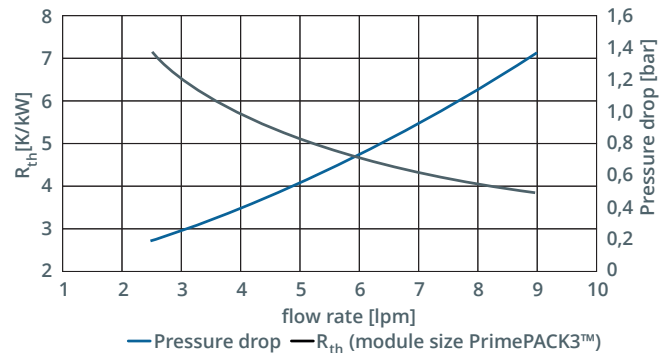

Easy combinations. Diverse liquid cooling solutions.

DAU EASY SYSTEM

DAU Easy was especially developed for IGBT applications. Numerous different liquid heat sinks can be produced by combining different water channel styles (style 1-7).

The positions of the water channels are set up in such a way that 98% of all power semiconductors currently available can be installed.



Type- Overview

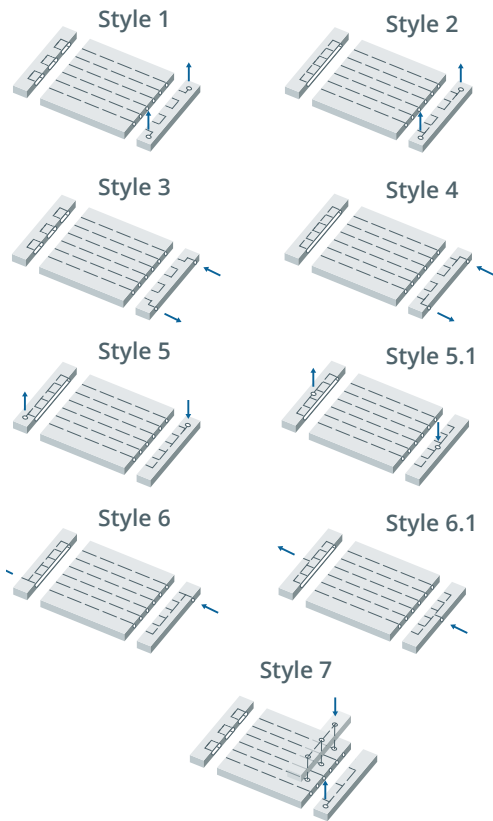

Mechanical Dimensions

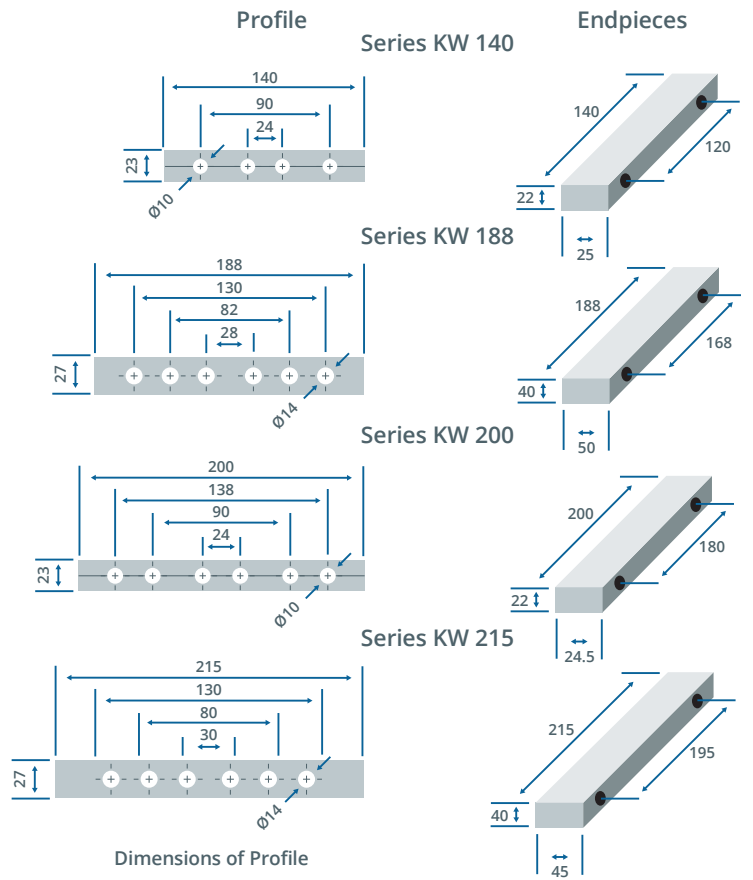

DAU KS WATER COOLING SYSTEM

The advantage of the KS water cooling system is the versatility. It is not only possible to adapt the water passages to the thermal requirements individually but the positions of the water inflow and run-off can also be individually chosen.

Typical Water Flow Patterns (Standard)

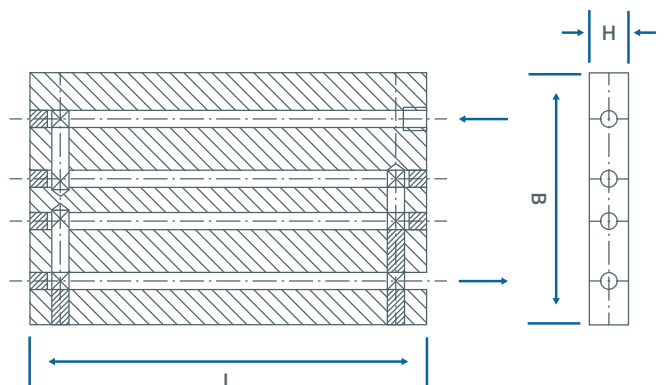
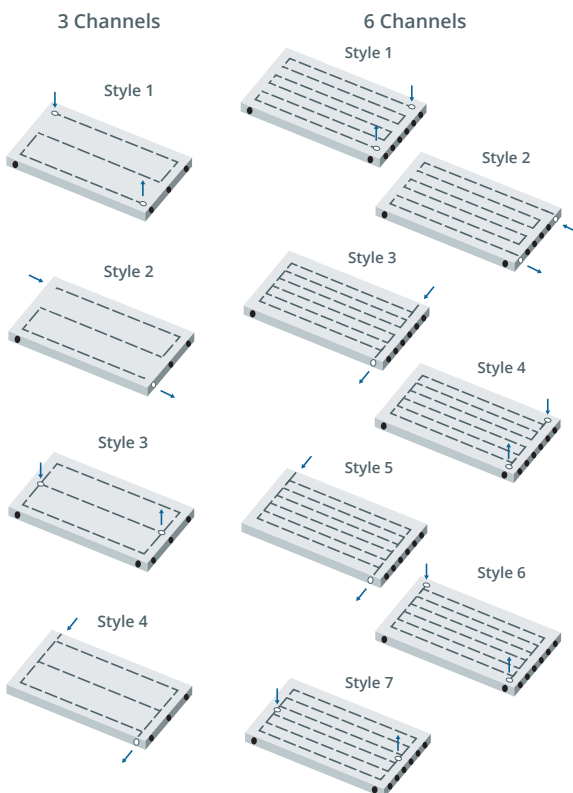

KLD WATER COOLING SYSTEM

DAU has a wealth of experience in bending pipes and even holds a patent for the insertion of pipes into aluminum plates. The KLD series by DAU provides almost unlimited possibilities in terms of channel flow. Pipes made of copper and stainless steel of various diameters may also be used.

KL WATER COOLING SYSTEM

The KL series was developed as a more affordable alternative to the KLD series. Pipes of copper or stainless steel are pressed into the surface and provide a direct contact with the cooling elements. The thermal resistance can be reduced using smaller components

Air cooling heat sinks for lower cooling requirements.

BONDED FIN HEAT SINKS

Various length, fin heights, special shapes and surface finishes are used according to the requirements.

The IHM / IHV series was developed especially for IGBTs with the following dimensions: 130 mm x 140 mm and 190 mm x 140 mm.

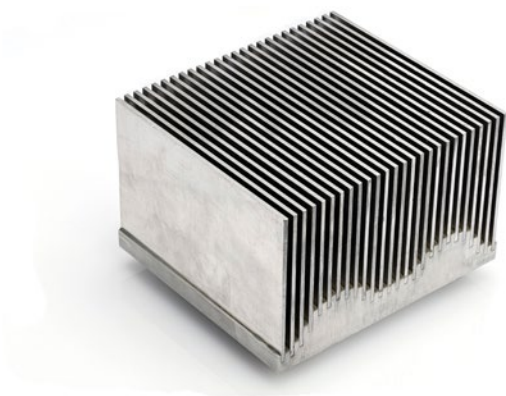
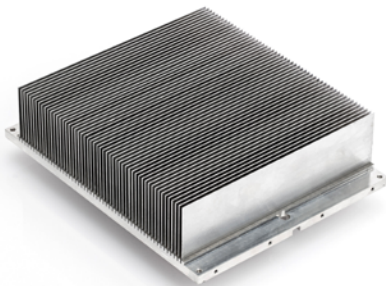

SOLDERED FIN HEAT SINKS

The soldered air cooling heat sinks of the SF series are suitable for components, where a very small surface is subjected to very intense heat and therefore requires effective cooling. Due to the thermal conductivity of the copper (as opposed to aluminium) which is twice as high, the fin effectiveness of the SF series is considerably better than conventional heat sinks.

PRESSED FIN HEAT SINKS

Unlike the BF series, the fins in the PRE / PRE series are not joined using a thermal glue. Instead they are assembled using a patented cold welding process with a base plate. By doing so, the thermal contact resistance is reduced to a minimum.

Values of up to 0.022 K/W (measured directly underneath the module) are possible, regardless of the size of the semiconductor and the volume flow.



HIGH DENSITY EXTRUDED HEAT SINKS

As a producer of high-performance heat sinks, DAU also offers Friction Stir Welding (FSW), along with other bonding techniques, in order to produce large heat sinks cost-effectively.

By welding individual base elements, it is possible to produce heat sinks of up to 1200 mm in width.

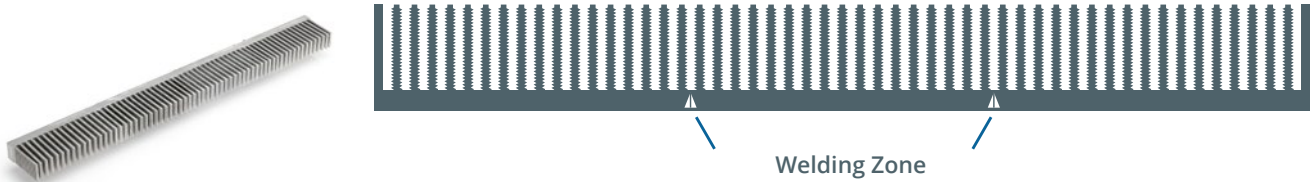

Comprehensive service. Comprehensive satisfaction.

We have been representing DAU in Switzerland for over 20 years. As there are no good off-the-shelf cooling solutions, DAU has evolved into a solution specialist for thermal problems in power applications.

Based on customer requirements, cooling technology and production methods are drawn up on paper. These are then checked using models, simulations and prototypes as part of the second stage. This multistage process is the reason for the success of DAU heat sinks.

You can find more detailed information about DAU heat sink solutions in the DAU product catalogue.



Philipp Helfenstein
CEO

Direct: +41 44 751 80 50
Mobile: +41 79 669 88 33
philipp.helfenstein@etronics.ch



Thomas Badat
Account Manager

Direct: +41 44 751 80 58
Phone: +41 44 751 80 51
thomas.badat@etronics.ch